

REQ/M

REQ/M is an ultra-compact microprocessor based regulation unit for automatic power factor control systems, with relay outputs for driving up to 6 capacitor banks.

The unit has been designed to ensure high accuracy in power factor regulation and excellent utilization of capacitor banks and relays, even in presence of high environmental noise and strongly distorted current signals specific of industrial plants.

The regulator can be installed on three-phase 50 or 60 Hz networks with direct or quadrature insertion, through a CT (current transformer) to get the line current. It is also possible to apply the unit on mono-phase networks. All input circuits are internally galvanically insulated each other.

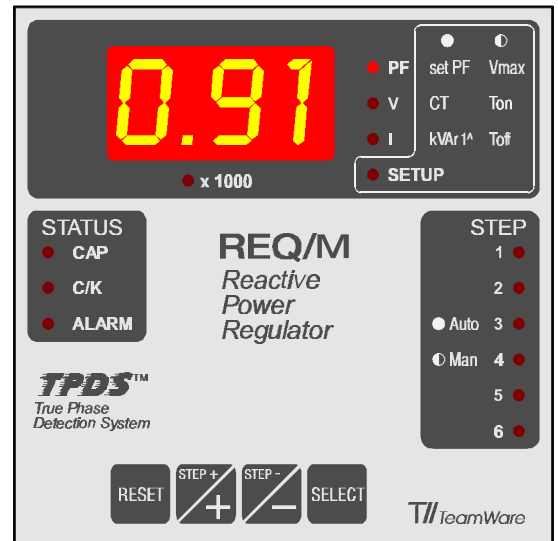

The front panel is equipped with a 3-digits 7 segments display to show the present value of power factor, voltage and line current: it makes possible to avoid the installation of other panel meters (voltmeters and ammeters) on the power rack.

A complete set of panel leds notifies the device status, which capacitor banks are inserted, the power factor region (ind/cap) and if the automatic regulation is active (C/K). By means of four pushbuttons it is possible to display the measures, to setup the unit, to make manual operations on capacitor banks and reset alarms.

The regulator is provided with many protection features, by a monitoring of the following quantities:

- line voltage: an alarm is issued when it exceeds the threshold programmed value for a time longer than 30 minutes;
- line current: an alarm is issued when it exceeds +20% more than nominal value;
- power factor: an alarm is issued if the power factor is not properly corrected within 15 minutes.

When an alarm is issued, the alarm led lights on and the alarm relay contact is open (optional). Alarms are automatically reset when the alarm condition disappears: nevertheless, if more than 3 alarms occur within one hour, a manual reset is requested, to notify an abnormal condition with a possible fault into the electrical system

The **TPDS™** (*True Phase Detection System*) technology applied to voltage and current signals processing allows the regulator to operate accurately even with strongly distorted waveforms: using an advanced digital processing approach the unit is able to keep out from all harmonic components only the fundamental sinusoidal voltage and current waveforms, to evaluate the relative phase lag for the correct reactive power regulation.

Available Models

- REQ/M4 4 steps
- REQ/M6 6 steps

- REQ/M4-A 4 steps with alarm relay
- REQ/M6-A 6 steps with alarm relay

Main Specifications

- ABS case, 96 x 96 mm
- Auxiliary power supply 110/230 V~
- Voltage input 80/500 V~
- Frequency selectable between 50 Hz or 60 Hz
- Quadrature (three-phase networks) or direct (mono-phase) wiring
- Current input via standard CT /5A
- True RMS current and voltage measure even with harmonics
- Power factor setting range from 0.85ind. to 095cap.
- Primary current setting range from 5 A to 10000 A
- 1st capacitor bank setting range from 1 kVAR to 999kVAR
- insertion and disconnection times for capacitor banks independently programmable
- non volatile storing of setup parameters
- 3 digit display for power factor, line voltage, line current
- manual operation on capacitor banks with non volatile storing of manoeuvres
- voltage alarm thresholds programmable
- current alarm thresholds fixed at +20 % of nominal current
- alarm relay output (NC) (optional)

Front Panel

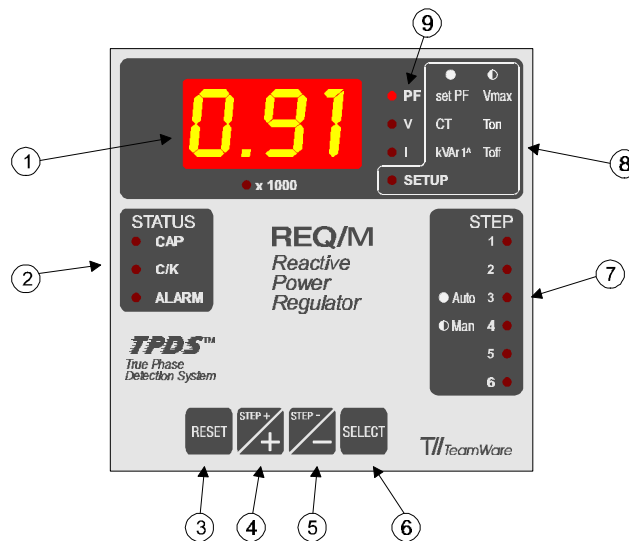

- (1) LED display for power factor, voltage and current showing
- (2) Status LED: cap/ind power factor, C/K active, alarm
- (3) Manual reset
- (4) Increment setup parameter value / manual insertion of capacitor bank
- (5) Decrement setup parameter value / manual disconnection of capacitor bank
- (6) Select measure or setup parameter
- (7) Step status LED
- (8) Description table for setup parameters
- (9) Pointer LED to measure or setup parameter currently displayed

Front Panel Display and Keys

MEASURE LED	
⊗ PF, V, I	Indicate the currently displayed measure (PF, voltage, current) (<i>Note that the SETUP led is Off</i>).
⊗ x 1000	Multiplier x 1000 for displayed value.

STATUS LED	
⊗ CAP	When on, it means capacitive PF.
⊗ C/K	<u>On</u> : the line current has a value able to permit the automatic PF regulation <u>Blink</u> : the line current is under the minimum value to permit the automatic PF regulation. In this case the step condition remains unchanged. <u>Off</u> : line current is under the lowest current that the regulator can measure. In this case the capacitor banks are detached.
⊗ ALARM	Blinks together with the led corresponding to the alarmed measure, to indicate an alarm condition reached by one or more measures.

SETUP LED	
⊗ set PF, V, I, Vmax, Ton, Toff	Indicate the currently displayed setup parameter (<i>note that the SETUP led is On</i>): <ul style="list-style-type: none"> ▪ 1st level parameters (led On): PF set-point, CT primary current, 1st (lowest) step kVAR (referred to nominal voltage). ▪ 2nd level parameters (led Blink): maximum voltage threshold, insertion time, disconnection time (seconds).

KEYS	
RESET	<ul style="list-style-type: none"> ▪ during the normal operating mode, forces an alarm reset; ▪ during a setup session, forces the default value for the currently displayed parameter. ▪ during the power on, forces the default value for all the parameters.
+	<ul style="list-style-type: none"> ▪ during a manual operation, inserts the selected capacitor bank. If pressed twice, the insertion will be permanently stored in non volatile memory (blinking led). ▪ during a setup session, increments the value of currently displayed parameter.
-	<ul style="list-style-type: none"> ▪ during a manual operation, disconnects the selected capacitor bank. ▪ during a setup session, decrements the value of currently displayed parameter.
SELECT	<ul style="list-style-type: none"> ▪ during the normal operating mode, selects the measure to be displayed. ▪ during a manual operation, selects the bank to be manually operated.

SPECIAL KEYS	
(two keys pressed together)	
SELECT with +	If pressed for 5 sec., enter the setup session.
SELECT with -	If pressed in normal operating mode, fix the currently displayed measure as default display after power on (default PF).
RESET with +	If pressed in normal operating mode, they start a cyclic scanning of the measures on display (loop time 3 sec.)
+ with a -	They start the manual operation on banks.

Programming the unit

To program the unit, press the keys **SELECT** and **+** together for a time longer than 5 sec. The regulator will disconnect recursively the connected capacitor banks and then will light on the setup led.

The programmable parameters are the following:

1st level parameters (led ON):

- PF set-point (from 0.85 ind. to 0.95 cap.)
- CT primary current (from 5 to 10000 A)
- 1st (lowest) capacitor bank kVAr (from 1 to 999 kVAr), referred to voltage nominal value

2nd level parameters (led blinking):

- maximum voltage threshold (from 80 to 540 V)
- delay between two consecutive step insertions (when PF is below the set-point) (from 5 to 60 sec.)
- delay between two consecutive step disconnections (when PF is over the capacitive limit) (from 5 to 60 sec.)

Using the keys **SELECT**, **+**, **-**, it is possible to select and modify the value of each parameter. The parameter currently being modified is marked by the corresponding led (for 2nd level parameters the led is blinking). Look at the description table on the front panel to have hints on setup parameters.

After 10 seconds from last key pressing, the setup session automatically finishes, the setup led lights off and the regulator will come back to operating mode.

Selecting the line frequency

During the power on sequence, the unit prompts the line frequency to work:

F50 : 50 Hz (default)

F60 : 60 Hz

It is possible to select the line frequency between 50 and 60 Hz. To program the line frequency, keep pressed during the power-on the keys **RESET** and **-**: the regulator alternatively toggles from 50 to 60 Hz frequencies.

The carried out selection is permanently stored into a non-volatile memory, until modified again.



Note that it is absolutely required to set the regulator for the effective line frequency, otherwise an improper service will result.

Selecting the wiring type

During the power-on sequence, the unit prompts the wiring type:

3 Ph : three-phase wiring (quadrature) (default)

1 Ph : mono-phase wiring

It is possible to select the wiring type between quadrature and direct. To program the wiring type, keep pressed during the power-on the keys **RESET** and **+**: the regulator alternatively toggles between three-phase and mono-phase wiring.

The carried out selection is permanently stored into a non-volatile memory, until modified again.



Note that it is absolutely required to set the regulator for the wiring effectively performed, otherwise an improper service will result..

How the regulator operates

The regulator computes the true RMS measure of voltage and current signals and obtains the phase lag between their fundamental components. That measure is obtained from active (real) and reactive power values averaged on 5 seconds time, to guarantee accuracy and stability even with distorted waveforms.

Using the **SELECT** key it is possible to display the measured values of PF, line voltage and current. The corresponding led indicates the displayed measure.

Pressing together the **RESET** and **+** keys, the display will do a cyclic scan of all the measures, with 3 sec. of pause time. Press any key to suspend the autoscan.

If the computed PF is capacitive, the led CAP will light on.

If there is no current or voltage signal, the PF cannot be evaluated. In this case the display prompts like this:

If the computed PF results in a lower value than the required one, the regulator will insert, after the programmed insertion time, the next available capacitor step. If the computed PF is over the upper threshold (see below), the regulator will detach (if any) the next capacitor step. If the PF remains within the low and high thresholds, the regulator keeps unchanged the capacitor banks configuration.

The upper PF threshold is fixed to 5 points over the programmed low set-point.

The attaching/detaching strategy always takes the first not-attached/attached capacitor step starting from bottom.

Examples:

PF set-point (lower threshold)	Corresponding upper PF threshold
0.88 ind.	0.93 ind.
0.90 ind.	0.95 ind.
0.96 ind.	0.99 cap.
0.98 ind.	0.97 cap.
0.99 ind.	0.96 cap.
1.00	0.95 cap.
0.98 cap.	0.93 cap.

Step attaching sequence					
1	2	3	4	5	6
X					
X	X				
X	X	X			
X	X	X	X		
X	X	X	X	X	
X	X	X	X	X	X

Step detaching sequence					
1	2	3	4	5	6
X	X	X	X	X	X
	X	X	X	X	X
		X	X	X	X
			X	X	X
				X	X
					X

C/K handling

The automatic reactive power regulation by means of connection/disconnection of capacitor banks is operated only if the measured line current exceeds the equivalent C/K value (reactive current equivalent to 1st capacitor bank load): in this case the C/K led is ON.

If the current is below the C/K corresponding one, the unit will keep unchanged the capacitor banks configuration: in this case the C/K led is blinking.

In case of very low current (lower than 2% of C/K current), the regulator will detach all the steps: in this case the C/K led is OFF.

Manual operation

It is possible to operate manually on capacitor banks: pressing together the keys + and – the regulator prompts on the display the step to be manually controlled, starting from bottom:

BO1

Use the **SELECT** key to select which is bank to be manually operated and the + or - keys to attach or detach it.

Pressing twice the key + the manual insertion becomes permanently stored (even after a power down): this case is represented by the corresponding blinking led. Use the key – to remove the bank.

Alarms

In case of alarm, the regulator behaves as follows:

- maximum voltage (voltage level exceeds the programmed threshold for a time longer than 30 min.): the unit disconnects all the steps (including the ones manually inserted), lights on the alarm led, opens the alarm relay contact (optional), and forces blinking the voltage led;
- current overload (line current beyond 6 A into the current circuit for more than 3 sec.): the unit lights on the alarm led, opens the alarm relay contact (optional), and forces blinking the current led;
- not compensated PF (PF compensation not achieved within 15 min.): the unit lights on the alarm led, opens the alarm relay contact (optional), and forces blinking the PF led, but continuing the normal operation.

When the alarm event disappears, the regulator automatically drops from alarm condition: however if more than 3 alarms occur within one hour, the unit will require a manual reset of alarm, to notify an abnormal condition with possible fault into the electrical system.

To manually reset the alarm, press the **RESET** key for 3 seconds.

Wiring diagram

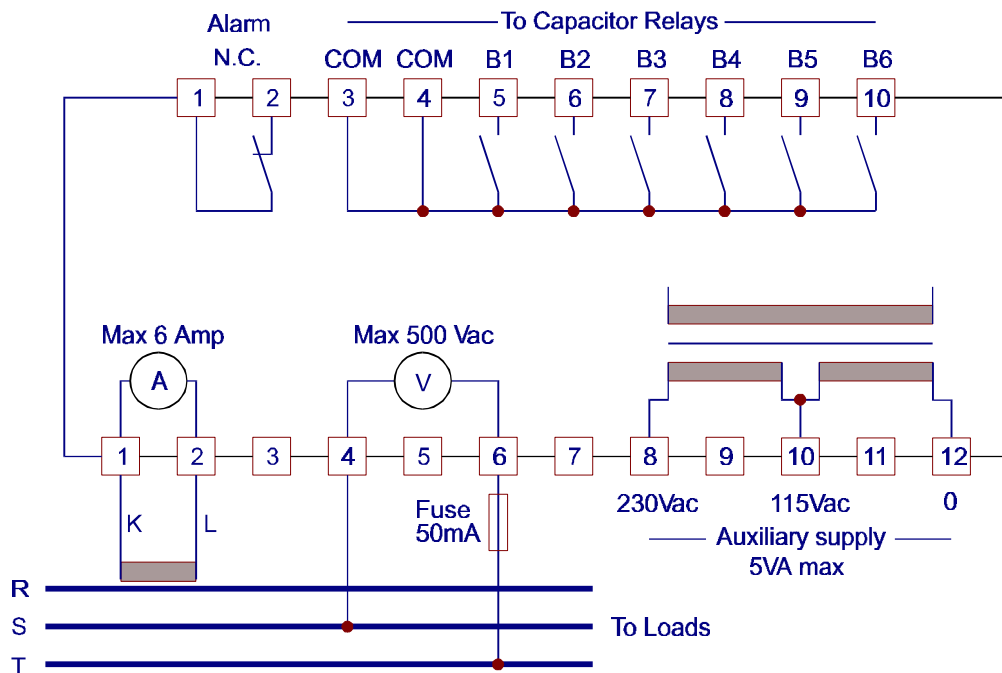

The unit must be installed, disinstalled, wired to mains circuit only by qualified personnel, aware of involved risks.

During the installation and disinstallation of the unit, remove voltage from electric circuit.

Respect carefully the wiring diagram, because a wrong insertion can produce damage to device and persons or an improper service.

*The maximum contacts load for each relay is 5A: in case of loads with power greater than 5 A, **it is indispensable** to use power contactors connected to relay contacts.*

Technical Specifications

Power supply	110/230 Vac $\pm 10\%$
Frequency	50/60 Hz
Power consumption	4 VA
Voltage input	80/500 Vac
Current input (insulated)	From CT /5 A permanent overload +20% consumption 0.01 VA
Current input range	1-100% of nominal current
PF setting range	from 0.85 ind to 0.95 cap accuracy ± 1 digit
Display	3 digit 7 segments led type
Leds	Indication of: <ul style="list-style-type: none"> ▪ inserted steps ▪ measure displayed ▪ unit status
Step insertion time	from 5 to 60 sec.
Step disconnection time	from 5 to 60 sec.
Step relays	4/6 depending on model
Relay contacts	5 A - 250 Vac resistive load transients suppressor included
Connection terminals	Plug in connectors
Alarm relay (optional)	NC type, 5 A - 250 Vac contacts
Working temperature	0 \div 55 °C
Storing temperature	-10 \div 70 °C
Protection class	IP41 no cover
Standards	EN61010-1, EN50081-2, EN50082-2
Weight	0.5 kg
Size	96x96x60 mm

(Specifications subject to change without notice)

SIZE AND MOUNTING HOLES

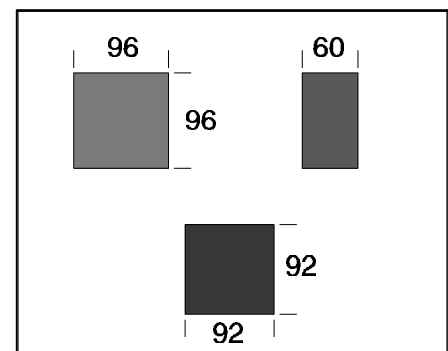

T//TeamWare

Via Pindaro, 19
20128 Milano - Italy
Tel. +39 2 27003261
Fax +39 2 2579982
E-mail: teamware@iol.it